

Allied Window Inc. **HOL** (Historic One Lite) INSTALLATION INSTRUCTIONS (800) 445-5411



Window Identification: All window units are identified with a steel stamping into the aluminum frames. They are stamped in the lower left hand corner of the frames & inserts. If supplied the H-Mulls & Deep Guide stops, and angle are stamped inside of these extrusions. Please layout all components to make sure order is complete.

Tools Needed: Tape Pencil, 3/16" drill bit, drill or battery drill, and a fresh # 2 Phillips tip.

Opening Preparation: Make sure that the mounting surface is free of nails, staples, screws, or excess old caulking.

Window Preparation: Holes will need to be drilled in the outer edge of storm window. With clips facing down using pencil & tape measure mark 4" up and 4" down on heights of window. Measure between the holes just marked and add additional holes evenly spaced 18" or less. At head of windows 36" and less mark 1 hole at center. Over 36" widths divide width by 3 so spacing is 18" or less. No holes required at sill. Once these holes have been laid out, using the 3/16" drill bit, drill holes in outer double wall edge. After drilling through first layer angle drill slightly towards the wood stop, this will keep wood stops from splitting during installation.

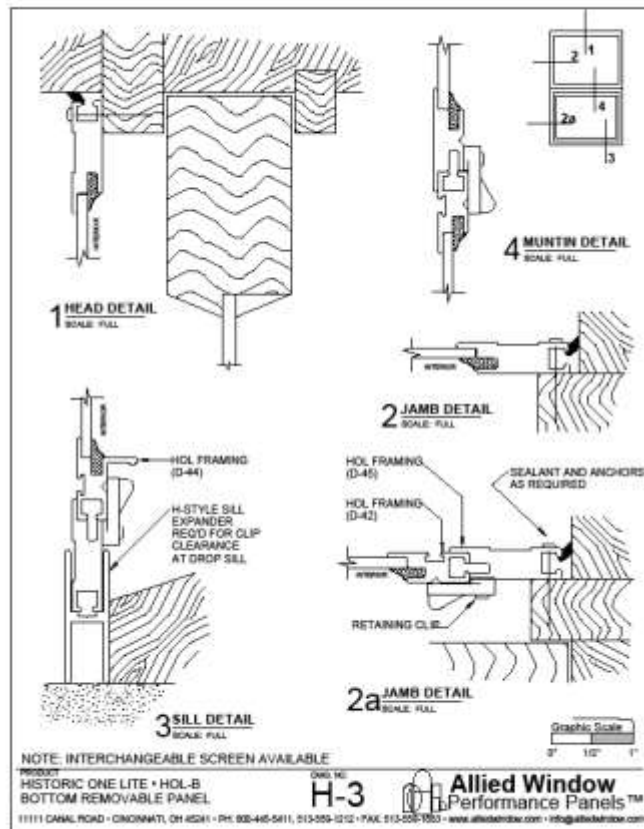

Installation:

- 1) Place H-Mull expander at sill with weep slots facing down, set storm window with glass inserts installed (this will keep window square) into expander. Tilt window into position, using the pry bar at the sill, lift the window and maintain a 1/8" perimeter at sides and head.
- 2) Apply screws, (painted Phillips head # 8 x 1" supplied by Allied Window)